

- 1
- 2
- 3
- 4
- 5
- 6
- 7
- 8
- 9
- 10
- 11
- 12
- 13
- 14
- 15
- 16
- 17
- 18

MAIN SPECIFICATIONS

- Aluminium
- Epoxy resin coating
- Black, RAL 9005, textured finish **SW**
- Sleeve bearing
- Plastic (PTFE)
- Socket cap screws DIN 912
- Stainless Steel AISI 304
- Hexagon nut DIN 985
- Stainless Steel AISI 304
- Self-locking via polyamide ring

FEATURES AND APPLICATIONS

Flanged linear actuator connectors GN 146.13 are based on flanged connector clamps. The additionally provided mounting holes are used to connect to the drive key of a linear actuator. Bores with the designation **G** are equipped with sleeve bearings. With the screw location **z**, the play of the guide bores d1 can be adjusted or the linear actuator connectors can be clamped after adjustment. For quick clamping without tools, the socket cap screw can be replaced by the adjustable hand levers GN 911 (see page).

ACCESSORY

Adjustable Hand Levers GN 911 (see page).

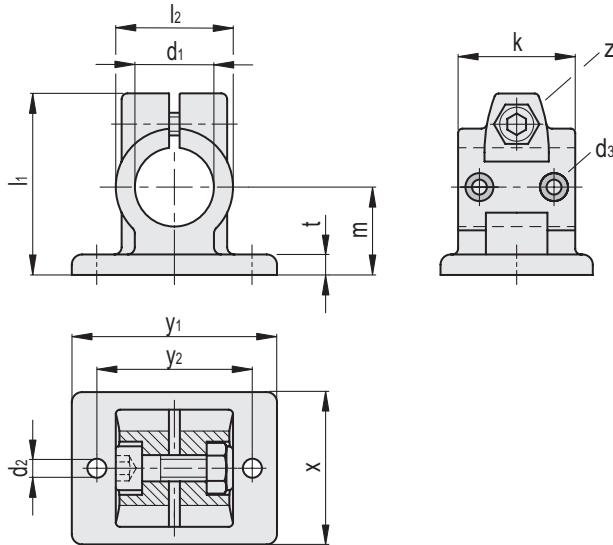
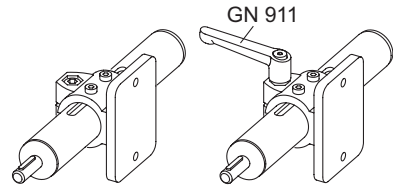
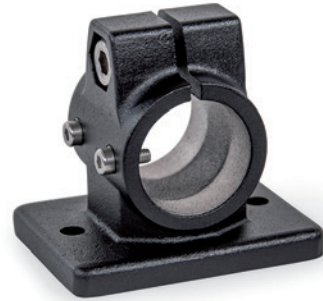

GN 146.13-B

Code	Description	d1 Bore without sleeve bearing	d2	d3	k	l1	l2	m	t	x	z	y1	y2	z Clamping kit	⚖
GN.46961	GN 146.13-B30-40-2-SW	B 30	6.5	M 4	40	62	40	30	7	52	M8-25	70	53	GN 911-63 / GN 911-78	159
GN.46962	GN 146.13-B30-56-2-SW	B 30	8.5	M 4	56	83	56	42	10	78	M10-35	108	82	-	511
GN.46963	GN 146.13-B40-56-2-SW	B 40	8.5	M 5	56	83	56	42	10	78	M10-35	108	82	GN 911-78 / GN 911-92	438

GN-146.13-G

Code	Description	d1 Bore with sleeve bearing	d2	d3	k	l1	l2	m	t	x	z	y1	y2	z Clamping kit	⚖
GN.46966	GN 146.13-G30-40-2-SW	G 30	6.5	M 4	40	62	40	30	7	52	M8-25	70	53	GN 911-63 / GN 911-78	159
GN.46967	GN 146.13-G30-56-2-SW	G 30	8.5	M 4	56	83	56	42	10	78	M10-35	108	82	-	511
GN.46968	GN 146.13-G40-56-2-SW	G 40	8.5	M 5	56	83	56	42	10	78	M10-35	108	82	GN 911-78 / GN 911-92	438

Tube connectors